



DOMINATOR **PLUS**

G3840FXP Single Pan Programmable Fryer with Filtration & Oil Level Sensor

Key features

- High efficiency burner system
 - Quick heat up and instant recovery times
 - Reduces energy consumption and running costs
- Automatic two-stage filtration built in
 - Increases oil longevity and maintains quality
- Stainless steel hob with mild steel pan
 - Robust construction to withstand busy demands
- Temperature range between 130 - 190°C
 - Variable, precise control
- Unique pan design requires just 18 litres of oil
 - Easy to clean as well as being energy efficient and saves money on oil
- Programmable controls
 - Adds convenience and ensures cooking times are adhered to
- Electric ignition to burner
 - Quick and easy lighting
- Fast-acting safety thermostat
 - Power cut to unit if oil overheats
- Supplied with fish grid, basket and lid
 - Everything you need to start frying
- Supplied with drain bucket, strainer and filter
 - Essential parts of the filtration process

Accessories

- Sidescreens
- Factory fitted, adjustable castors
- Fixed installation kit



Similar Models

- G3840F Single pan, twin basket fryer with filtration
- G9341F Single pan, twin basket fryer with filtration
- E3840FXP Single pan, twin basket programmable electric fryer with filtration & oil level sensor

FALCON **ANGEL FRYER**[®]

The unique *Falcon Angel Fryer* safety system prevents fryer fires, making it a must-have for any commercial kitchen.

The most common causes of fryer fire occur when oil levels are too low during cooking or when the appliance is switched on without the operator checking to see if there is enough oil in the pan. The *Falcon Angel Fryer* eradicates this by simply cutting power to the unit if the oil level is not at a sufficiently high level.

The Falcon Angel Fryer - making your kitchen safer!

UK Patent Serial No. GB2584184

Single Pan Programmable Fryer with Filtration & Oil Level Sensor

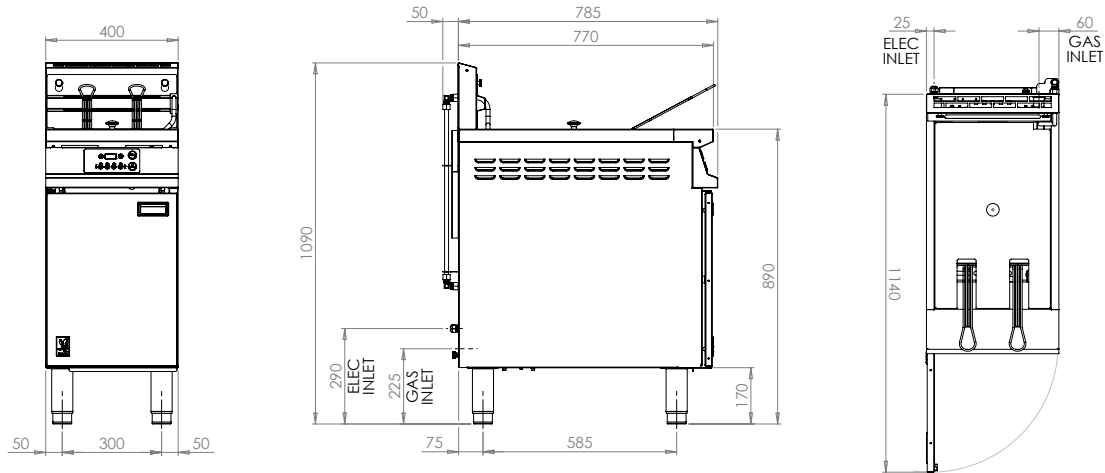

Measurements *in mm*

Unit on castors is the same hob height

Unit supplied with 2m main cable

Specification *details*

Total rating (natural and propane - kW - Nett)	23
Total rating (natural and propane - btu/hr - gross)	78,500
Electrical supply voltage	230V N~
Inlet size (natural and propane)	3/4" BSP
Flow rate - natural (m ³ /hr)	2.43
Flow rate - propane (kg/hr)	1.78
Inlet pressure (natural and propane - mbar)	20 / 37
Operating pressure (natural and propane - mbar)	15 / 34.5
Oil capacity (litres)	18
Hourly chip output (kg)	34
Weight (kg)	94
Packed weight (kg)	103
Packed dimensions (w x d x h - mm)	450 x 1000 x 1300

Installation notes

Adequate ventilation must be provided to supply sufficient fresh air for combustion and to allow easy removal of any such products that may present a risk to health. Please consult current legislation for details that relate to specific locations.

Install unit on a level, fireproof surface in a well-lit, draught free position. If floor is made of a combustible material, local fire requirements must be checked to ensure compliance.

A clearance of 150mm should be observed between appliance and any combustible wall.

