



DOMINATOR PLUS

E3845XP Twin Pan Programmable Fryer with Oil Level Sensor

Key features

- Two individually-controlled pans
 - Increases menu options through the additional flexibility
- High performance elements
 - Quick heat up and rapid recovery times
 - Reduces energy consumption and running costs
- 3 stage switch on (per pan)
 - Prompts operator to check oil level before switching fryer on
- Temperature range between 130 - 190°C
 - Variable, precise control
- Unique pan design requires just 10 litres of oil (per pan)
 - Easy to clean, energy efficient and saves money on oil
- Programmable controls
 - Adds convenience and ensures cooking times are adhered to
- Stainless steel hob with mild steel pans
 - Robust construction to withstand busy demands
- Fast-acting safety thermostat
 - Power cut to unit if oil overheats
- Supplied with fish grids, baskets and lid
 - Everything you need to start frying

Accessories

- Sidescreens
- Factory fitted, adjustable castors
- Fixed installation kit

Similar Models

- E3845F Twin pan fryer
- E3845F Twin pan fryer with filtration
- E3845FXP Twin pan programmable fryer with filtration & oil level sensor



FALCON ANGEL FRYER®

The unique *Falcon Angel Fryer* safety system prevents fryer fires, making it a must-have for any commercial kitchen.

The most common causes of fryer fire occur when oil levels are too low during cooking or when the appliance is switched on without the operator checking to see if there is enough oil in the pan. The *Falcon Angel Fryer* eradicates this by simply cutting power to the unit if the oil level is not at a sufficiently high level.

UK Patent Serial No. GB2584184

Twin Pan Programmable Fryer with Oil Level Sensor

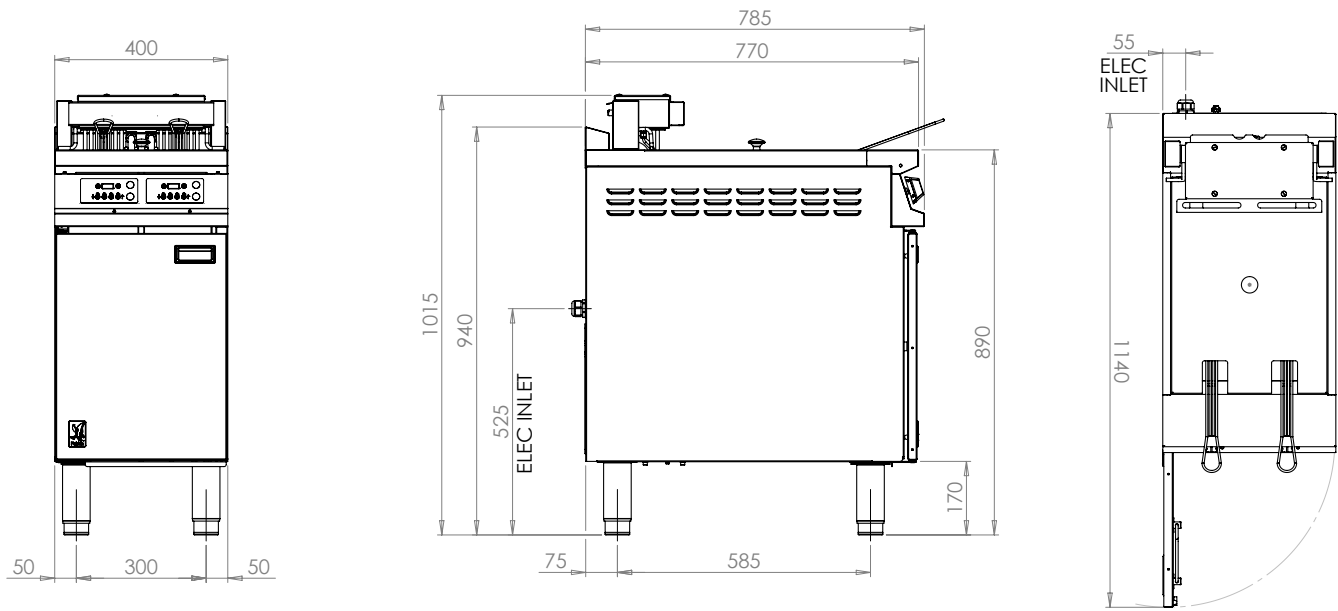

Measurements *in mm*

Unit on castors is the same hob height

Specification *details*

Dimensions (w x d x h - mm)	400 x 770 x 890
Electrical rating (kW)	20
Electrical supply voltage	400V 3N~
Required electrical supply 400V (A)	32
Electrical current split (A)	L1: 29 L2: 29 L3: 29
Oil capacity (litres)	2 x 10
Hourly chip output (kg)	2 x 25
Weight (kg)	83
Packed weight (kg)	92
Packed dimensions (w x d x h - mm)	450 x 1000 x 1100

Installation notes

Adequate ventilation must be provided to supply sufficient fresh air and to allow easy removal of any such products that may present a risk to health. Please consult current legislation for details that relate to specific locations.

Install unit on a level, fireproof surface in a well-lit position. If floor is made of a combustible material, local fire requirements must be checked to ensure compliance.

A clearance of 150mm should be observed between appliance and any combustible wall.

