



## DOMINATOR PLUS

# E3845F2X Twin Pan Fryer with Twin Filtration & Oil Level Sensors

### Key features

- Two individually-controlled pans
  - Increases menu options through the additional flexibility
- Automatic two-stage filtration per pan built in
  - Increases oil longevity and maintains quality
  - Reduced risk of oil contamination, making it ideal for cooking specific foods in (ie allergen free, vegan etc)
- High performance elements
  - Quick heat up and rapid recovery times
  - Reduces energy consumption and running costs
- 3 stage switch on (per pan)
  - Prompts operator to check oil level before switching fryer on
- Temperature range between 130 - 190°C
  - Variable, precise control
- Unique pan design requires just 10 litres of oil (per pan)
  - Easy to clean, energy efficient and saves money on oil
- Stainless steel hob with mild steel pans
  - Robust construction to withstand busy demands
- Fast-acting safety thermostat
  - Power cut to unit if oil overheats
- Supplied with fish grids, baskets and lid
  - Everything you need to start frying
- Supplied with drain buckets, strainers and filters
  - Essential parts of the filtration process

### Accessories

- Sidescreens
- Factory fitted, adjustable castors
- Fixed installation kit

### Similar Models

- E3845F2 Twin pan fryer with twin filtration
- E3845FX Twin pan fryer with filtration & oil level sensor
- E3845FXP Twin pan programmable fryer with filtration & oil level sensor



## FALCON ANGEL FRYER®

The unique *Falcon Angel Fryer* safety system prevents fryer fires, making it a must-have for any commercial kitchen.

The most common causes of fryer fire occur when oil levels are too low during cooking or when the appliance is switched on without the operator checking to see if there is enough oil in the pan. The *Falcon Angel Fryer* eradicates this by simply cutting power to the unit if the oil level is not at a sufficiently high level.

UK Patent Serial No. GB2584184

## Twin Pan Fryer with Twin Filtration & Oil Level Sensors

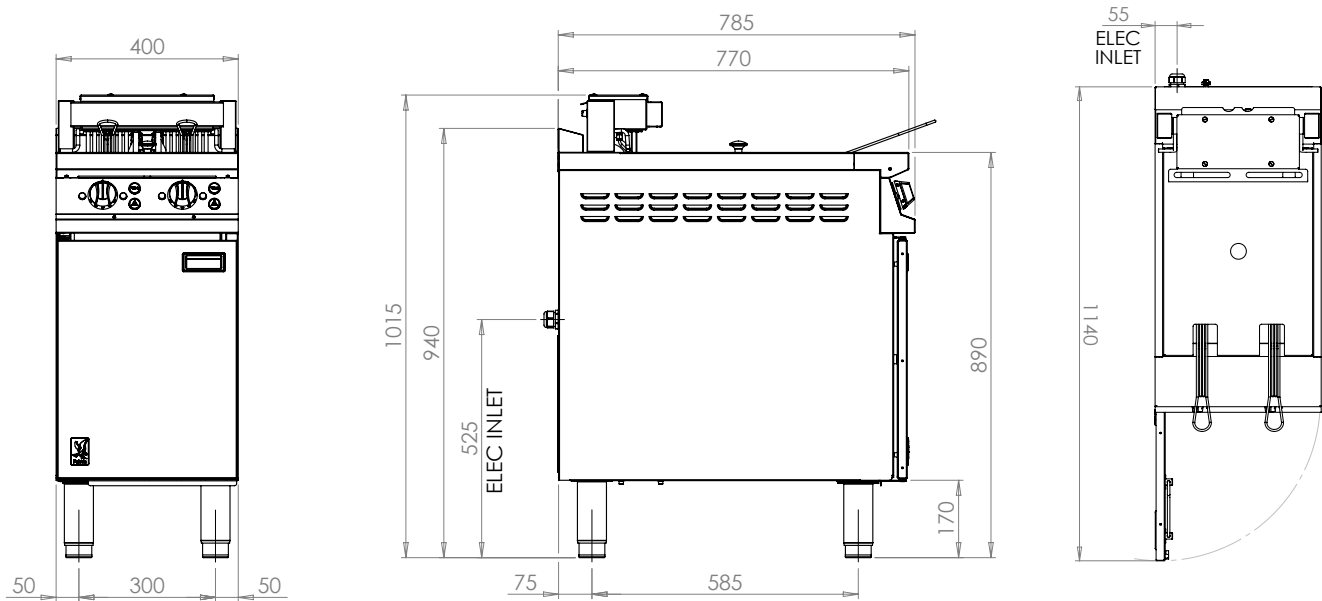

Measurements *in mm*

Unit on castors is the same hob height

## Specification details

Electrical rating (kW)	20
Electrical supply voltage	400V 3N~
Required electrical supply 400V (A)	32
Electrical current split (A)	L1: 29 L2: 29 L3: 29
Oil capacity (litres)	2 x 10
Hourly chip output (kg)	2 x 25
Weight (kg)	83
Packed weight (kg)	92
Packed dimensions (w x d x h - mm)	450 x 1000 x 1100

## Installation notes

Adequate ventilation must be provided to supply sufficient fresh air and to allow easy removal of any such products that may present a risk to health. Please consult current legislation for details that relate to specific locations.

Install unit on a level, fireproof surface in a well-lit position. If floor is made of a combustible material, local fire requirements must be checked to ensure compliance.

A clearance of 150mm should be observed between appliance and any combustible wall.

