



## **DOMINATOR**PLUS

# *E3840FP Twin Basket Programmable Fryer with Filtration*

### Key features

- Automatic two-stage filtration built in
  - Increases oil longevity and maintains quality
- Programmable controls
  - Adds convenience and ensures cooking times are adhered to
- Stainless steel hob with mild steel pans
  - Robust construction to withstand busy demands
- Temperature range between 130 - 190°C
  - Variable, precise control
- Sediment collection zone
  - Keeps oil cleaner for longer
- Resting position for elements
  - Allows easier, safe cleaning
- Fast-acting safety thermostat
  - Power cut to unit if oil overheats
- Drain bucket supplied as standard
  - Mounted upon slide for easy withdrawal
- Large diameter drain valve
  - Simple and efficient pan draining
- Supplied with fish grid, basket and lid
  - Everything you need to start frying

### Accessories

- Sidescreens
- Factory fitted, adjustable castors
- Fixed installation kit

### Similar Models

- E3840 Single pan, twin basket fryer
- E3840 Twin basket fryer
- E3840FX Twin basket fryer with filtration



# Twin Basket Programmable Fryer with Filtration

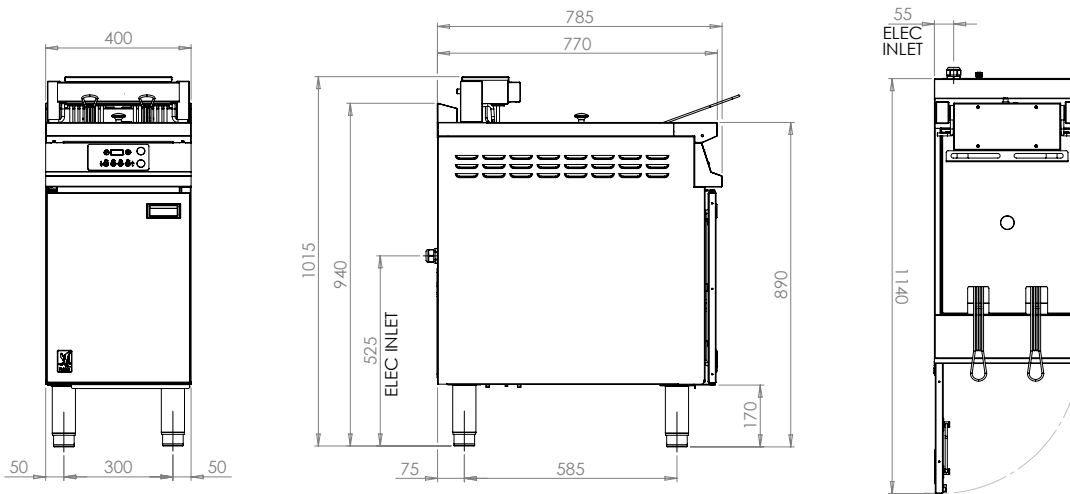

Measurements *in mm*

Unit on castors is the same hob height

## Specification *details*

Electrical rating (kW)	20
Electrical supply voltage	400V 3N~
Required electrical supply 400V (A)	32
Electrical current split (A)	L1: 29 L2: 29 L3: 29
Oil capacity (litres)	20
Hourly chip output (kg)	58
Weight (kg)	77
Packed weight (kg)	85
Packed dimensions (w x d x h - mm)	450 x 1000 x 1100

## Installation notes

Adequate ventilation must be provided to supply sufficient fresh air and to allow easy removal of any such products that may present a risk to health. Please consult current legislation for details that relate to specific locations.

Install unit on a level, fireproof surface in a well-lit position. If floor is made of a combustible material, local fire requirements must be checked to ensure compliance.

A clearance of 150mm should be observed between appliance and any combustible wall.

