



DOMINATORPLUS

H3925 Hydrogen Gas Radiant Chargin

Key features

- 3 x 8kW cast iron burners
 - Quick heat up, reduced waiting time
- Reversible, angled, heavy duty cast iron brander bars
 - Delivers even heat across entire cooking surface
- Full width cooking area
 - Maximum output
- Independently controlled burners
 - Vary heat across unit if required or even turn one side off during quieter periods
- Removable stainless steel surround
 - Ensures adjacent equipment remains spatter free
- Grease collection tray at front of unit
 - Catches and contains grease and fat
- Full width debris collection tray below unit
 - Catches all grease and debris
- Large capacity grease collection container
 - Easy to remove and empty during service
- Cast iron burners with variable control / turndown
 - Ensures chargin is at the desired temperature
- Laser-etched control icons
 - Permanent, indelible markings

Accessories

- Griddle plate
- V bars
- Fixed stand
- Factory fitted, adjustable castors
- Fixed installation kit

Other Hydrogen Models

- H3101 six burner oven range
- H3860F twin basket fryer with filtration
- H3641 smooth griddle
- H3532 salamander grill



Hydrogen Gas Radiant Charngrill

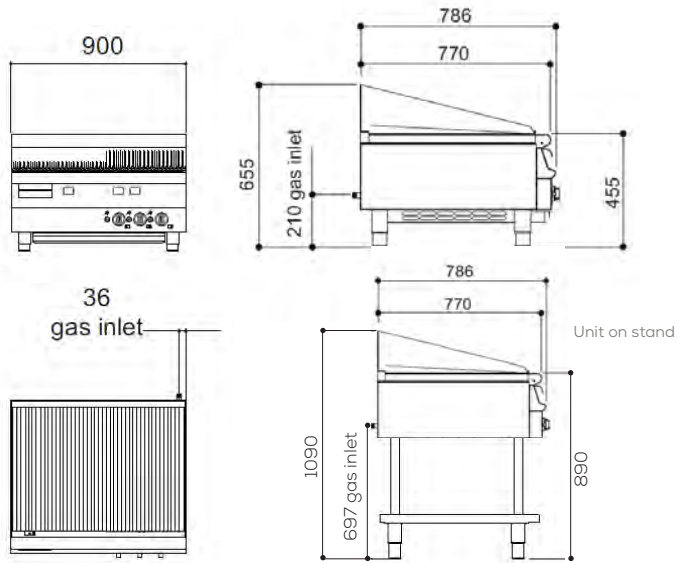

Measurements *in mm*

Unit on castors is the same hob height

Installation notes

Adequate ventilation must be provided to supply sufficient fresh air for combustion and to allow easy removal of any such products that may present a risk to health. Please consult current legislation for details that relate to specific locations.

Install unit on a level, fireproof surface in a well-lit, draught free position. If floor is made of a combustible material, local fire requirements must be checked to ensure compliance.

A clearance of 150mm should be observed between appliance and any combustible wall.

Specification *details*

Total rating (kW - Nett)	24
Inlet size	3/4" BSP
Flow rate (m ³ /hr)	8.46
Inlet pressure (mbar)	20
Operating pressure (mbar)	15
Cooking area (w x d - mm)	860 x 630
Number of burners	3
Number of brander bars	9
Weight (kg)	205
Weight on stand (kg)	235
Packed weight (kg)	219
Packed dimensions (w x d x h - mm)	1000 x 1000 x 650
GTIN number	5056466907471

