



# F900 SERIES

User, Installation and Servicing Instructions

## COUNTERTOP GRIDDLES

E9541, E9541R, E9541CR, E9581, E9581R, E9581CR

Read these instructions before use

DATE PURCHASED:

MODEL NUMBER:

SERIAL NUMBER:

DEALER:

SERVICE PROVIDER:

T100948

REV 10

Dear Customer,  
Thank you for choosing Falcon Foodservice Equipment.

This manual can be downloaded from [www.falconfoodservice.com](http://www.falconfoodservice.com) or scan here.



**IMPORTANT:** Please keep this manual for future reference.

## Falcon Foodservice Equipment

### HEAD OFFICE

Wallace View, Hillfoots Road,

Stirling, FK9 5PY, Scotland

Tel: 01786 455200

### PREVENTATIVE MAINTENANCE CONTRACT

To obtain maximum performance from this unit regular servicing of the appliance should be undertaken to ensure correct operation, it is functioning as intended, and safe to use. We recommend servicing in accordance with SFG20 Maintenance Schedules and as a minimum, after 2,500 hours of use, or annually, whichever comes first and that a maintenance contract be arranged with an appointed service contact. Visits may then be made at agreed intervals to carry out adjustments and repairs.



### WEEE Directive Registration No. WEE/DC0059TT/PRO

At end of appliance life, dispose of appliance and any replacement parts in a safe manner, via a licensed waste handler. Appliances are designed to be dismantled easily and recycling of all material is encouraged whenever practicable.

## SYMBOLS.



• SPANNER



• SCREWDRIVER



• COOKING OIL



• GREASE

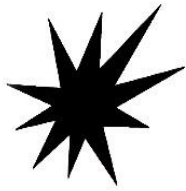

• SPARK IGNITION



• FLAME



• WARNING



• VIEWPORT



• ALLEN KEY



• IGNITER



• C SPANNER





- **These instructions are only valid if the country code appears on the appliance. If the code does not appear on the appliance, refer to the technical instructions for adapting the appliance to the conditions for use in that country.**
- **Installation must meet national or local regulations. Attention must be paid to: safety (installation & use) regulations, health and safety at work act, local and national building regulations, fire precautions act.**
- **To prevent shocks, all appliances must be earthed.**
- **This appliance has been UKCA/CE marked based on compliance with the relevant Electrical and Electromagnetic Compatibility (EMC) Regulations/Directives for the voltages stated on the data plate.**
- **This equipment is for professional use only and must be used by qualified persons.**
- **The installer must instruct the responsible person(s) of the correct operation and maintenance of the appliance.**
- **Only competent persons are allowed to service this appliance.**
- **Unless otherwise stated, parts which have been protected by the manufacturer must not be adjusted by the installer.**
- **Take care when moving an appliance fitted with castors.**
- **The appliance must be serviced regularly by a qualified person. Service intervals should be agreed with the service provider.**
- **Check that no damage has occurred to the appliance, power cable, or plug during transit. If damage has occurred, do not use this appliance.**
- **Installation, periodic testing, repair, and fixed wiring connections should only be undertaken by a competent electrician.**
- **Ensure power cable is routed free from the appliance to avoid damage.**
- **We recommend supplementary electrical protection with the use of a type A residual current device (RCD)**
- **The appliance has been designed and approved to use Falcon Kick plates, non Falcon kick plates could potentially adversely affect the performance of the appliance by restricting the air to the appliance.**

# CONTENTS

1.0	APPLIANCE INFORMATION .....	6
2.0	OPERATION .....	7
2.1	COMPONENT PARTS .....	7
2.2	USING THE GRIDDLE.....	7
3.0	CLEANING AND MAINTENANCE .....	8
4.0	SPECIFICATION.....	9
5.0	DIMENSIONS / CONNECTION LOCATIONS.....	10
6.0	INSTALLATION .....	11
6.1	SITING / CLEARANCES .....	11
6.2	ASSEMBLY .....	13
6.3	COMMISSIONING.....	14
6.4	SUITING .....	15
7.0	SERVICING.....	17
7.1	CONTROL PANEL REMOVAL.....	17
7.2	ELEMENT TRAY REMOVAL .....	18
7.3	OPERATING THERMOSTAT REMOVAL.....	19
7.4	ELEMENT REMOVAL.....	20
7.5	SAFETY THERMOSTAT REMOVAL (CHROME GRIDDLE ONLY) .....	20
7.6	SAFETY THERMOSTAT RESET (CHROME GRIDDLE ONLY).....	21
7.7	CIRCUIT DIAGRAMS.....	22
7.8	WIRING DIAGRAMS.....	26
8.0	FAULT FINDING.....	30
9.0	SPARE PARTS.....	30
10.0	SERVICE INFORMATION.....	31

# 1.0 APPLIANCE INFORMATION

This appliance has been UKCA/CE marked based on compliance with the relevant Electrical and Electromagnetic Compatibility (EMC) Regulations/Directives for the voltages stated on the data plate.

**Falcon Foodservice Equipment**  P.I.N.  STD.  

**A** Ser No.  **B** MODEL  **C** TYPE  I.P.

ES, GB, GR, IE, IT, PT, SI	BE, FR	BG, CZ, DK, EE, FI, HR, LT, LV, NO, RO, SE, SI, SK, TR	CY, HU, IS, MT, NL	AT, CH	PL	LU	DE	-
I2H3+	I3+	I2H3B/P	I3B/P	I2H3B/P	I2E3B/P	I2E	I2E3B/P	-
20;28-30/37	28-30/37	20;30	30	20;50	20;30	20	20;30	-

**D** Cat. **E** p mbar

GAS TYPE	G20	G30	G31	
GAS RATE	m <sup>3</sup> /h	kg/h	kg/h	
Σ Qn	kW	kW	kW	kW

**F** GAS TYPE **G** GAS RATE **H** Σ Qn

**I** EL.  Hz

**J** Σ kW  kW **K**  kHz

**L** L1 A L2 A L3 A

- A** - Serial No
- B** - Model No
- C** - Flue Type
- D** - Gas Category
- E** - Gas Pressure
- F** - Gas Type
- G** - Gas Rate
- H** - Total Heat Input
- I** - Electrical Rating
- J** - Total Electrical Power
- K** - Magnetic Field Frequency
- L** - Electrical Phase Loading

## 2.0 OPERATION

---

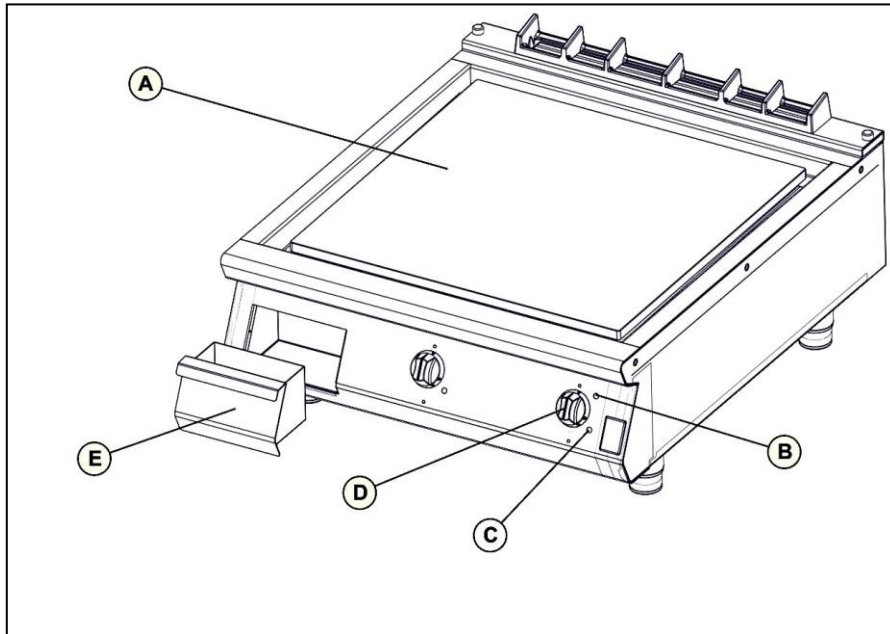

### 2.1 COMPONENT PARTS

- A – Griddle plate
- B – Power neon (red)
- C – Heat demand neon (amber)
- D – Thermostat control knob
- E – Fat jug

### 2.2 USING THE GRIDDLE

- 2.2.1 Before use, clean the appliance. See section 3.
- 2.2.2 Set temperature control to desired setting.
- 2.2.3 To switch the unit off, turn temperature control to `off` position.

## 3.0 CLEANING AND MAINTENANCE

---



**BEFORE ATTEMPTING ANY MAINTENANCE, ISOLATE THE APPLIANCE AT THE MAIN SWITCH AND TAKE STEPS TO ENSURE THAT IT IS NOT INADVERTENTLY SWITCHED ON.**

### MAINTENANCE CHECK



Regular servicing of the appliance should be undertaken to ensure correct operation, it is functioning as intended, and safe to use. We recommend servicing after 2,500 hours of use, or annually, whichever comes first.

Any maintenance schedule should be carried out in accordance with SFG20 Maintenance Schedule. Should any issues with the integrity of the components be identified these should be replaced. If the appliance is not considered safe the unit should be removed from service and the responsible person advised why the unit is not safe to use and what remedial action is needed. Contents of the maintenance schedule should be agreed with the maintenance provider.

- 3.1 Turn off and cool down.
- 3.2 Scrape off burnt on food.
- 3.3 Remove other debris using a cloth.
- 3.4 Clean fat jug.
- 3.5 The flue capper can be removed for cleaning, but must be replaced before use.

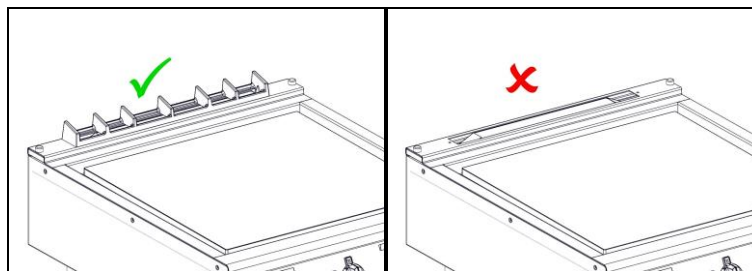

**DO NOT USE METAL UTENSILS ON CHROME GRIDDLE.**

**FAILURE DUE TO LACK OF PROPER CLEANING IS NOT COVERED BY WARRANTY.**



## 4.0 SPECIFICATION

---

- 4.1 This unit is suitable for AC supplies only
- 4.2 The standard terminal arrangement is Three phase (400V 3N~) for all variants.
- 4.3 To convert the appliance from three phase to single phase supply, insert links between phases 1, 2 and 3. Consideration must be given to required draw of current.

### **THIS APPLIANCE MUST BE EARTHED.**

Live 1 ( Phase 1)	Brown
Live 2 ( Phase 2)	Black
Live 3 ( Phase 3)	Grey
Neutral	Blue
Earth	Yellow/Green

E9541, E9541R, E9541CR

Phase	Min	Max	Actual (A)
L1	8.6	10.03	9.56
L2	8.6	10.03	9.56
L3			

E9581, E9581R, E9581CR

Phase	Min	Max	Actual (A)
L1	8.6	10.03	9.56
L2	17.2	20.07	19.12
L3	8.6	10.03	9.56



**IF ANY CURRENT IS OUT WITH THESE TOLERANCES, THE CAUSE MUST BE INVESTIGATED AND RECTIFIED.**

## 5.0 DIMENSIONS / CONNECTION LOCATIONS

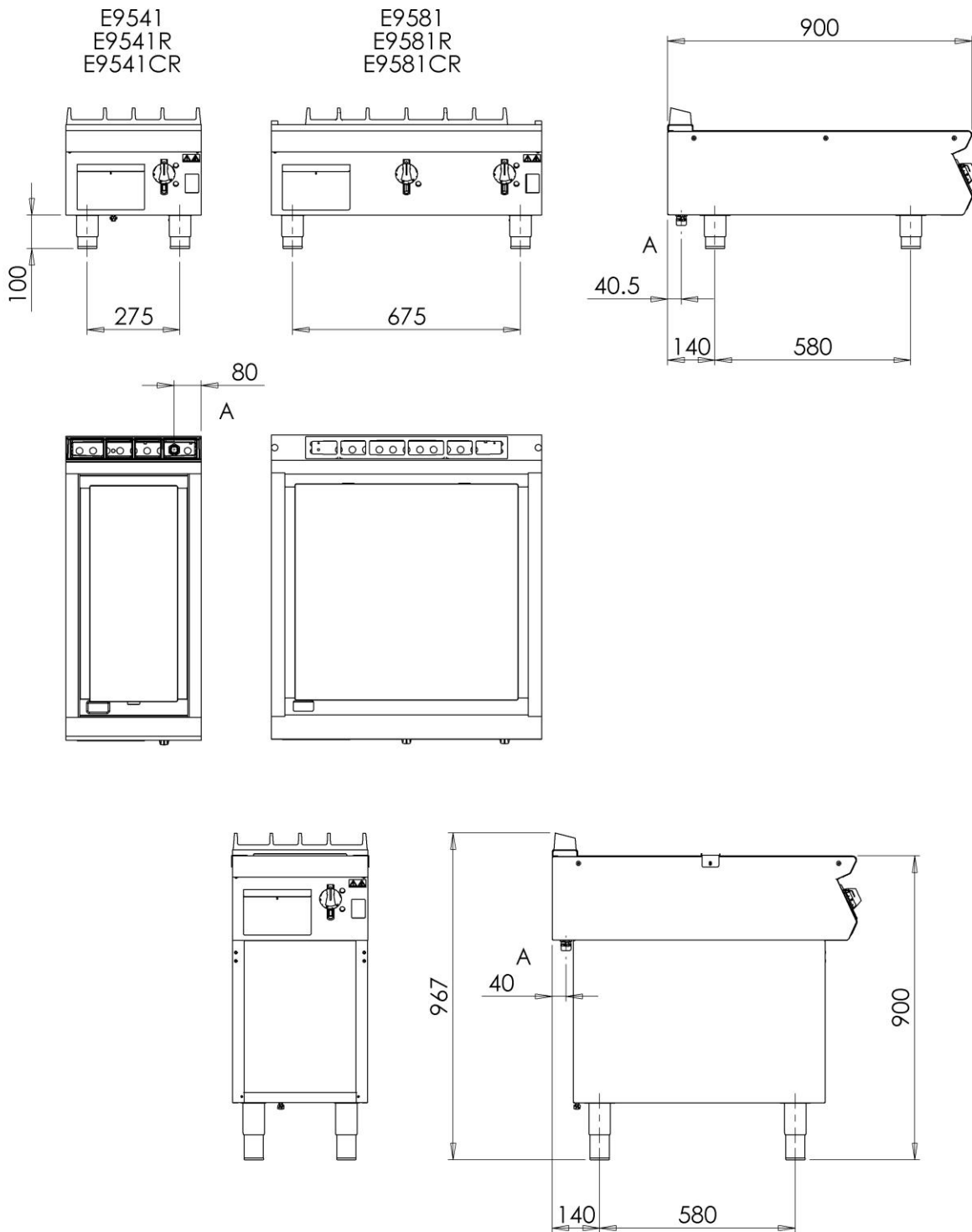

## 6.0 INSTALLATION

### Electrical Safety and Advice Regarding Supplementary Electrical Protection

---

Commercial kitchens and foodservice areas are environments where electrical appliances may be located close to liquids or operate in and around damp conditions or where restricted movement for installation and service is evident.

The installation and periodic inspection of the appliance should only be undertaken by a qualified, skilled, and competent electrician; and connected to the correct power supply suitable for the load as stipulated by the appliance data label.

The electrical installation and connections should meet the necessary requirements to the local electrical wiring regulations and any electrical safety guidelines.

#### **We recommend: -**

- Supplementary electrical protection with the use of a type A residual current device (RCD)
- Fixed wiring appliances incorporate a locally situated switch disconnecter to connect to, which is easily accessible for switching off and safe isolation purposes. The switch disconnecter must meet the specification requirements of IEC 60947.

#### **Your attention is drawn to:-**

#### **BS 7671:2018—Guidance Note 8 - 8.13 : Other locations of increased risk**

It is recognized that there may be locations of increased risk of electric shock other than those specifically addressed in Part 7 of BS 7671. Examples of such locations could include laundries where there are washing and drying machines in close proximity and water is present, and commercial kitchens with stainless steel units, where once again, water is present.

Where because of the perception of additional risks being likely, the installation designer decides that an installation or location warrants further protective measures, the options available include:

- Automatic Disconnection of Supply (ADS) by means of a residual current device having a residual operating current not exceeding 30mA;
- Supplementary protective equipotential bonding; and
- Reduction of maximum fault clearance time.

The provision of RCDs and supplementary bonding must be specified by the host organization's appointed installation designer or electrical contractor and installed by a suitably qualified and competent electrician so as to comply with Regulations 419.2 and 544.2

## 6.1 SITING / CLEARANCES

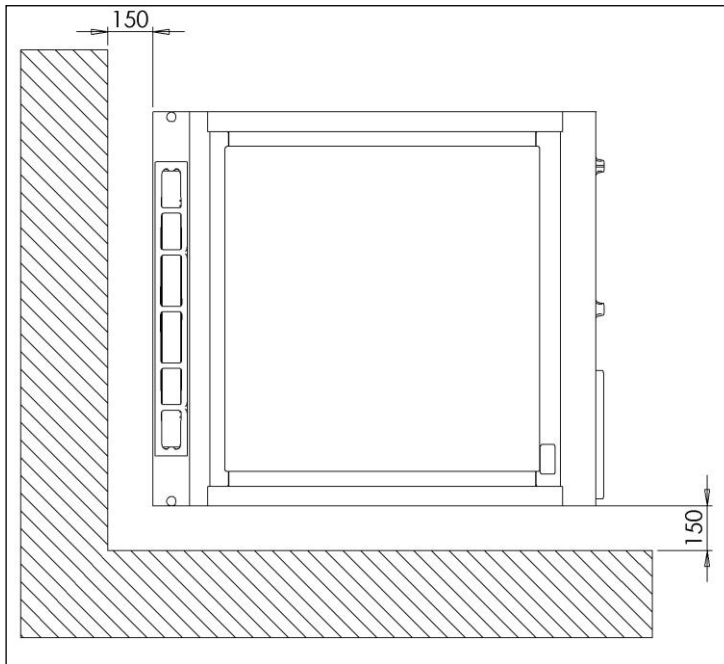

Where this appliance is to be positioned in close proximity to a wall, partitions, kitchen furniture, decorative finishes, etc., it is recommended that they be made of non-combustible material; if not, they shall be clad with a suitable non-combustible heat insulating material, and that the closest attention be paid to fire prevention regulations. If siting, the necessary clearances to any combustible wall must be the largest figure given for individual appliance instructions.

## 6.2 ASSEMBLY

6.2.1 Position appliance and level using feet adjusters as shown below. 400 wide models on stands should be fitted with the anti tilt device.

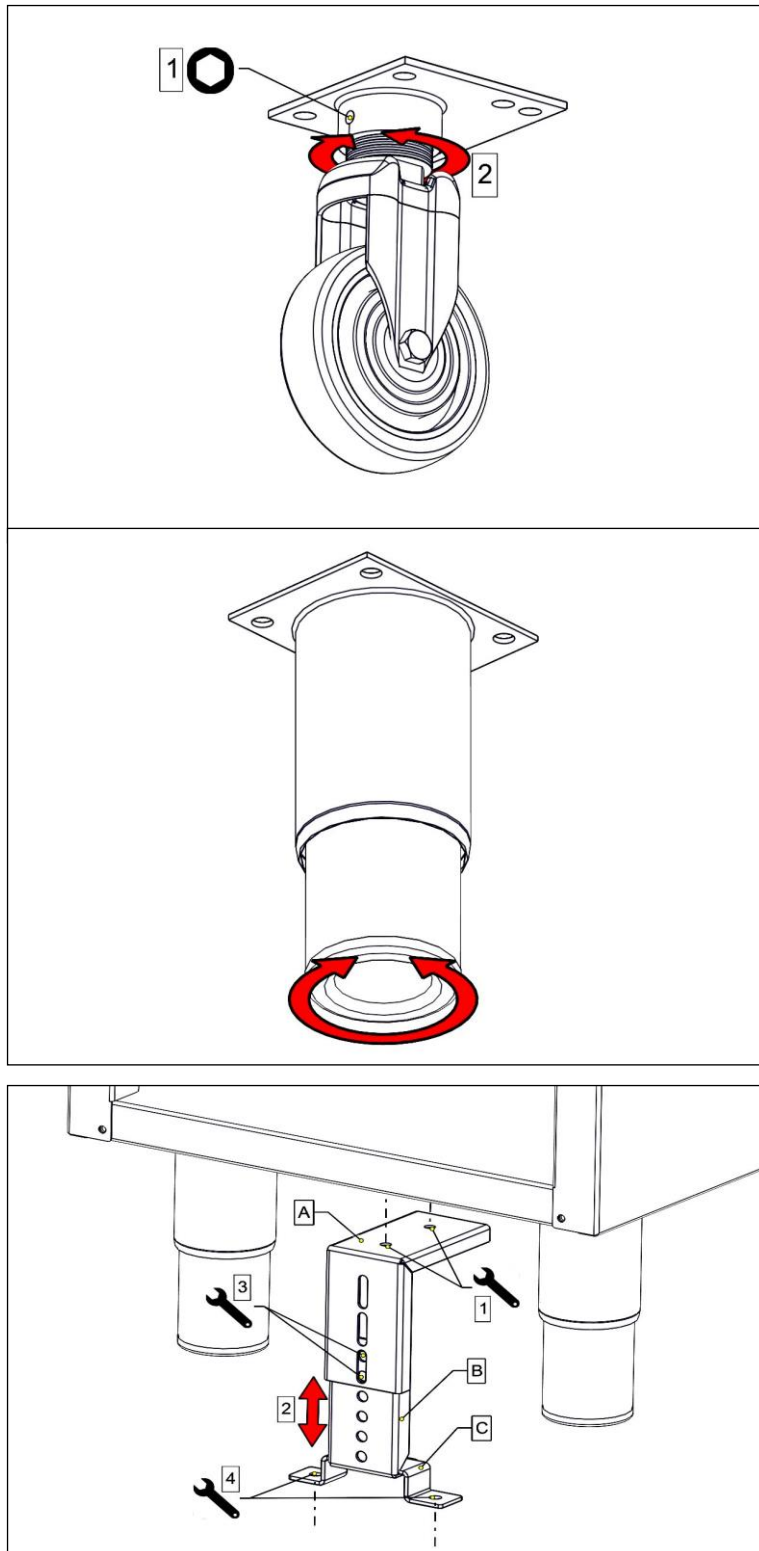

6.2.2 Connect appliance to mains supply

### 6.3 COMMISSIONING

- 6.3.1 Remove rear access plate and control panel.
- 6.3.2 Push the power cable through the gland and feed to the mains connector block.
- 6.3.3 Attach appropriate 3 phase mains power cable with 32A plug.
- 6.3.4 Refit rear access panel and control panel.
- 6.3.5 Connect appliance to mains power.
- 6.3.6 Ensure red neon illuminates.
- 6.3.7 Turn thermostat(s) to desired temperature.
- 6.3.8 Ensure amber neon(s) illuminates.
- 6.3.9 This appliance is also provided with a terminal for connection of an external equipotential conductor. This terminal is an effective electrical contact with all fixed exposed metal parts of the appliance, and shall allow the connection of conductor having a nominal cross-section area of up to 10mm<sup>2</sup>.  
it is located at the rear of the unit and identified by the following label and must only be used for bonding purposes.

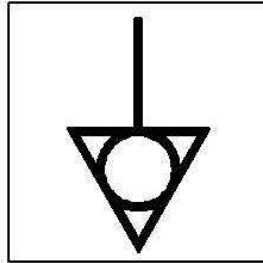

**PLEASE FILL OUT THE INFORMATION TABLE ON THE FRONT COVER AFTER COMMISSIONING.**

## 6.4 SUITING

**“Patent No. GB 2540131”**

- 6.4.1 Before leveling and suiting units ensure the units are fully built, including all accessories and castings.
- 6.4.2 Undo the 4 fixing screws on the control panel and remove.
- 6.4.3 Remove the hob rear infill and replace with rear suiting plate and fixings.
- 6.4.4 Remove the front side panel countersunk screw and suiting plate.

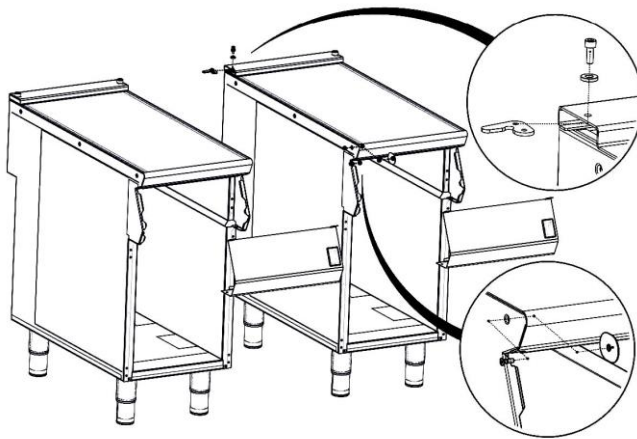

**NOTE:** The DLS system is designed to give a quick and easy suiting solution. If you require an improved seal between appliances we recommend you use, a food grade, high temperature silicon sealant. This can be supplied by Falcon part no – 523400021

- 6.4.5 If required, run a bead of silicon 5mm from profile edge as highlighted below.

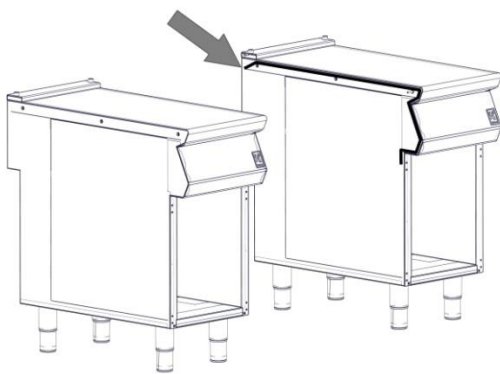

- 6.4.6 Slide suited units into position.

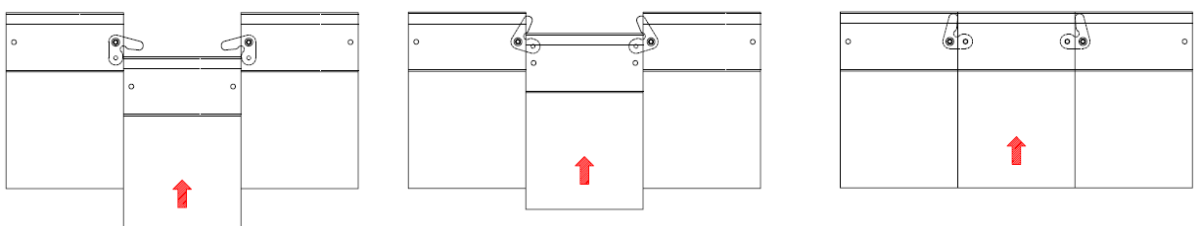

- 6.4.7 (A) Right hand unit: Screw the M5 x 40 screw (supplied in the kit) into one of the suiting plates as shown and then insert through the front fixing holes of both units.
- 6.4.8 (B) Left hand unit: Slide the penny and lock washer on to the screw and secure using the M5 nut.
- 6.4.9 (C) Remove the front bolts from feet, insert base tie plate and secure the bolts back into position.
- 6.4.10 (D) Replace fixings on the rear hob and tighten screw caps into position.

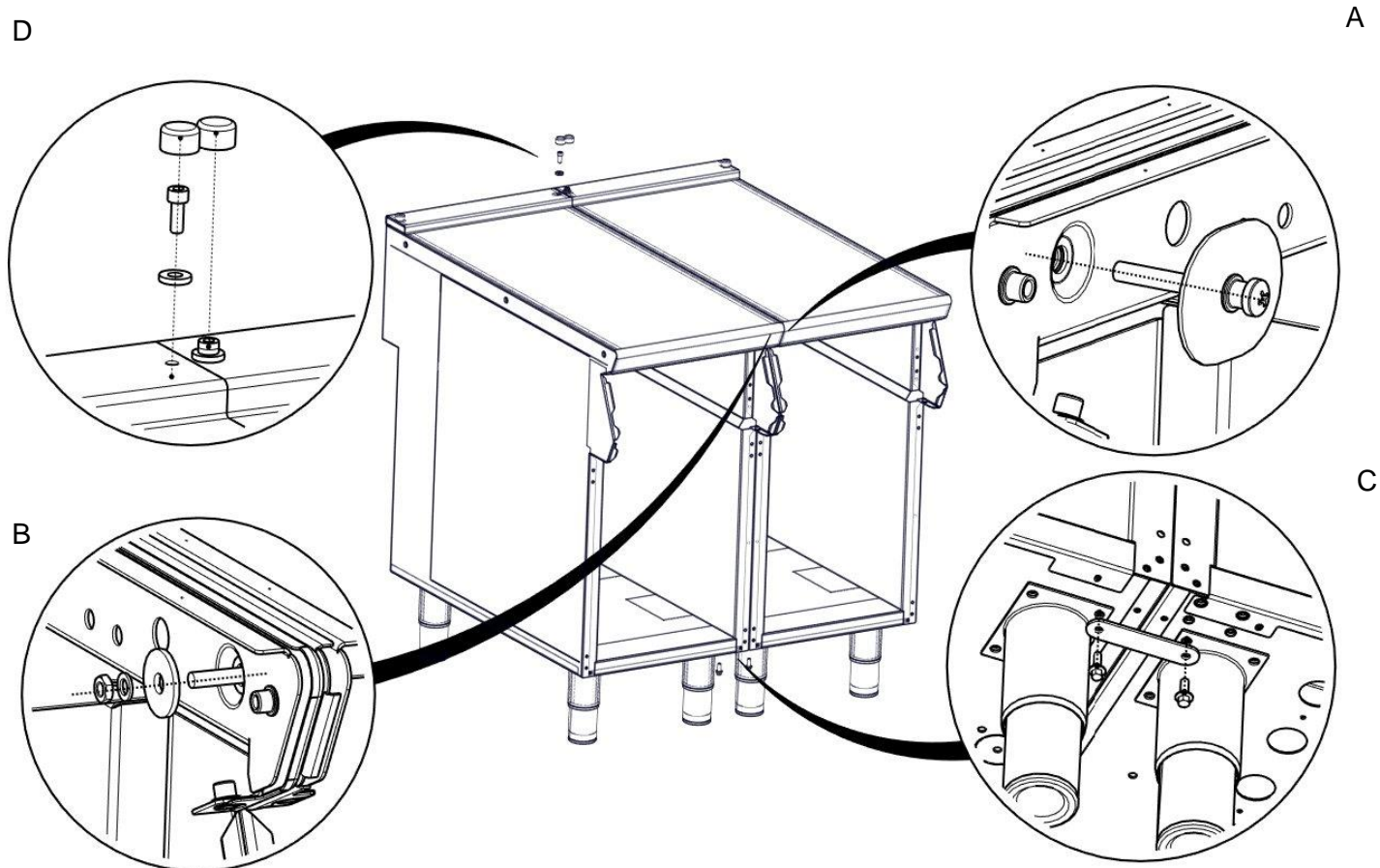

6.4.11 Replace control panel



## 7.0 SERVICING

---



BEFORE ATTEMPTING ANY MAINTENANCE, ISOLATE THE APPLIANCE AT THE MAINS SWITCH AND TAKE STEPS TO ENSURE THAT IT IS NOT INADVERTENTLY SWITCHED ON.

THE GRIDDLE PLATES ON THE E9500 SERIES ELECTRIC GRIDDLES ARE FIXED TO THE HOB PANEL AND ALL SERVICING SHOULD BE CARRIED OUT WITHOUT THE REMOVAL OF THE PLATE.

ALL ILLUSTRATIONS ARE BASED ON THE 800mm MODELS

### 7.1 CONTROL PANEL REMOVAL

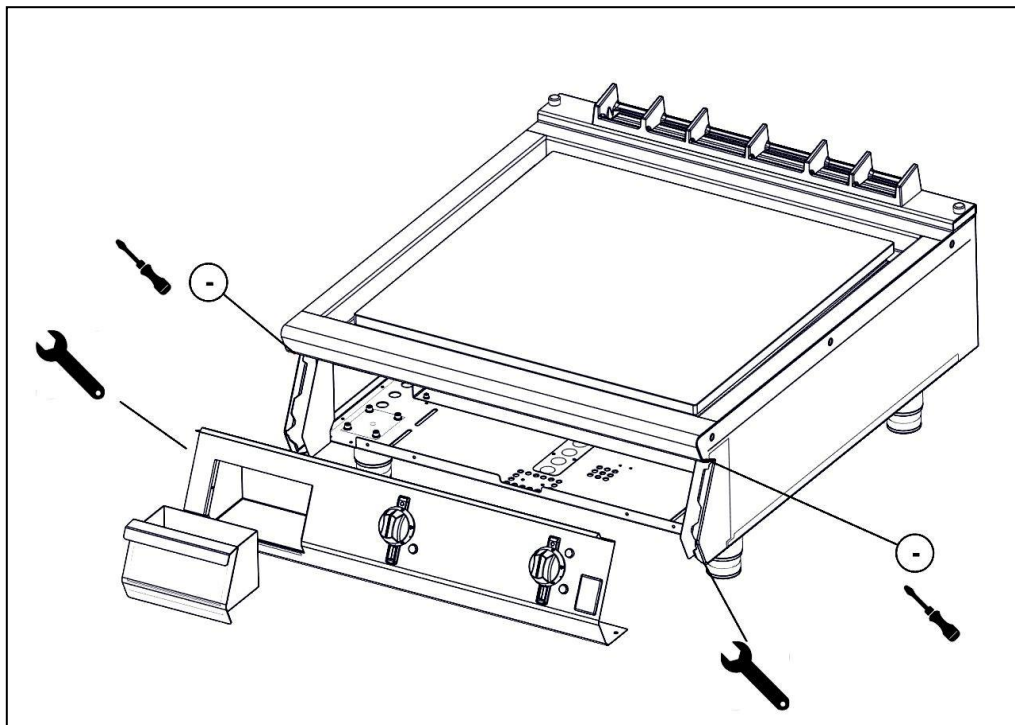

7.1.1 Remove panel as shown.

## 7.2 ELEMENT TRAY REMOVAL

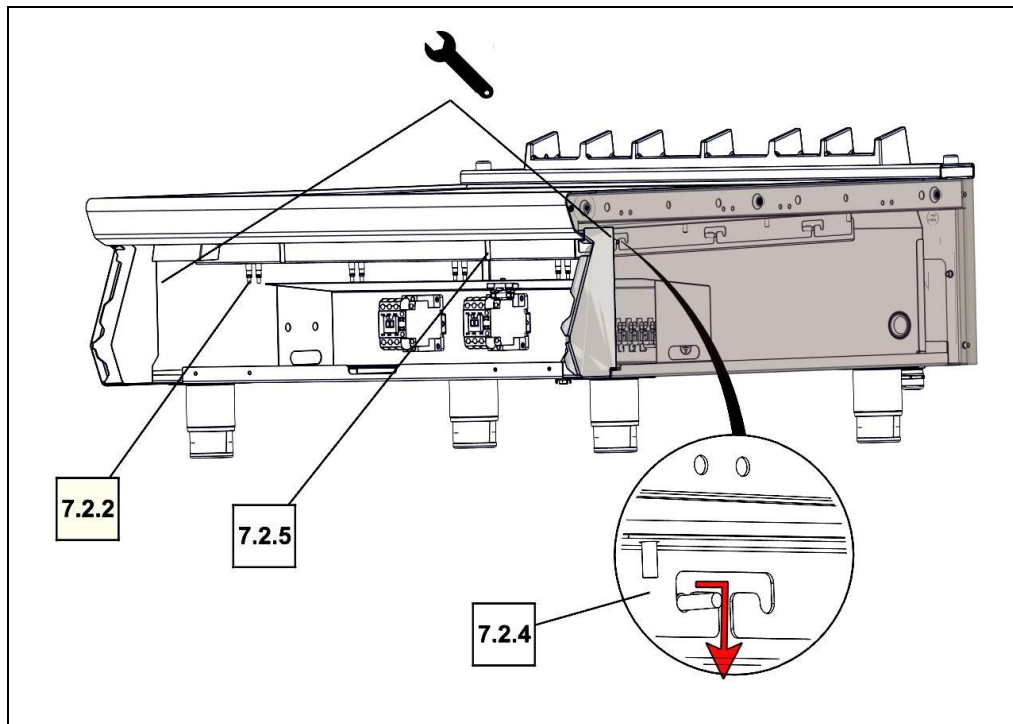

- 7.2.1 Remove control panel as shown in 7.1
- 7.2.2 Remove wiring from element tails.
- 7.2.3 Loosen the 2 front M5 nuts holding the element tray.
- 7.2.4 Lift up element tray and slide rearwards.
- 7.2.5 Lower tray free of mounting brackets ensuring thermostat capillaries clear their slots in tray.
- 7.2.6 Remove tray through front of appliance ensuring insulation does not snag on element tails.

### 7.3 OPERATING THERMOSTAT ON/OFF SWITCH REMOVAL

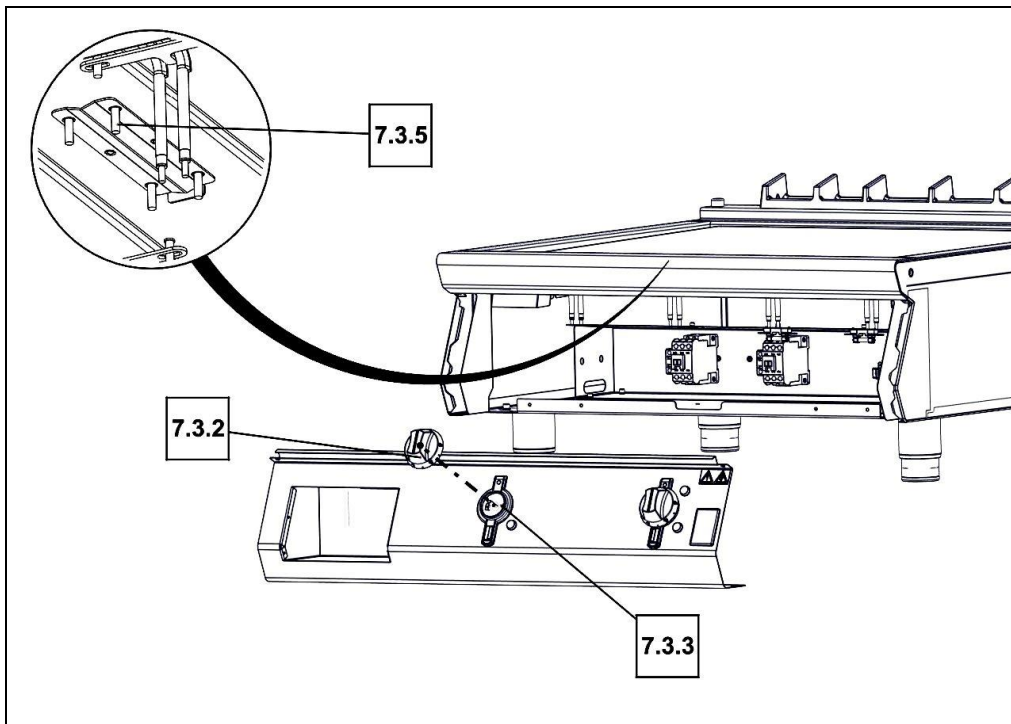

- 7.3.1 Remove control panel as shown in 7.1
- 7.3.2 Remove control knob.
- 7.3.3 Remove thermostat mounting screws.
- 7.3.4 Remove element tray as shown in 7.2
- 7.3.5 Loosen nuts on phial clamps.
- 7.3.6 Carefully pull phial forward free of the clamp.
- 7.3.7 When replacing the phial ensure you re-fit the vidaflex sleeve to the capillary and the phial is pushed fully in until it hits the end of the phial clamp before fully tightening the clamp nuts.

## 7.4 ELEMENT REMOVAL

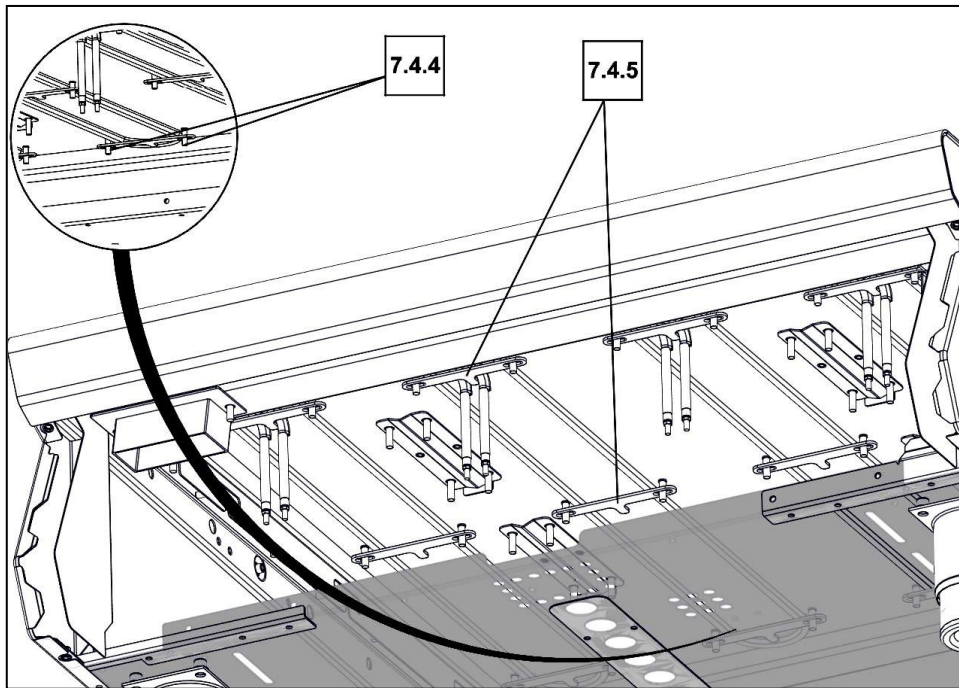

- 7.4.1 Remove control panel as shown in 7.1
- 7.4.2 Remove wiring from element tails.
- 7.4.3 Remove element tray as shown in 7.2
- 7.4.4 Loosen nuts on rear clamp.
- 7.4.5 Remove nuts and clamps from front & centre of element.
- 7.4.6 Slide element forward free of rear clamp.

## 7.5 SAFETY THERMOSTAT REMOVAL (CHROME GRIDDLE ONLY)

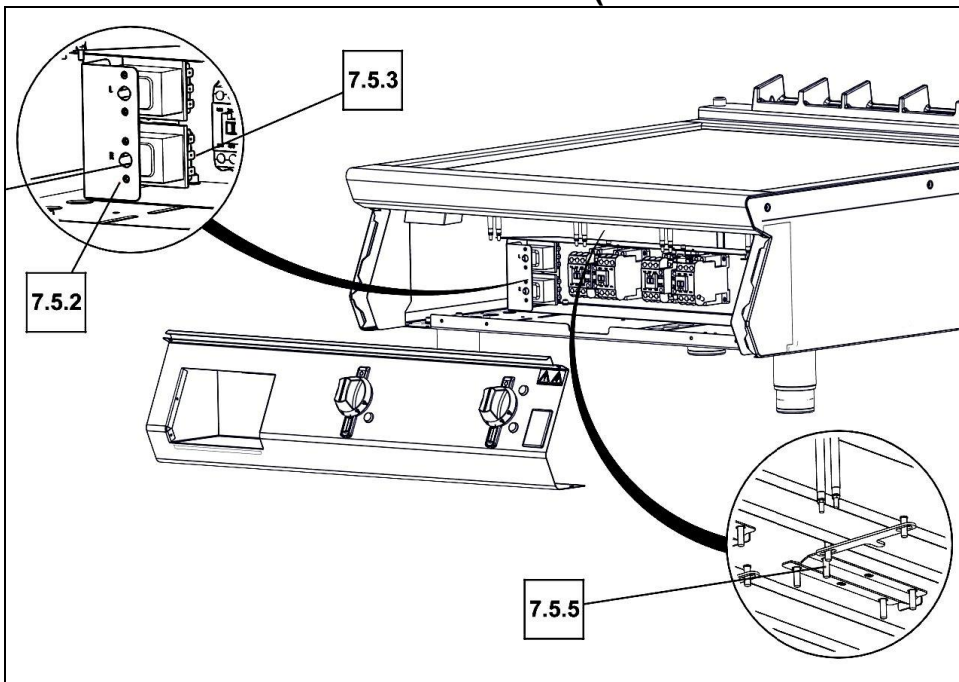

- 7.5.1 Remove control panel as shown in 7.1
- 7.5.2 Remove safety thermostat fixing screws.
- 7.5.3 Remove the wires from the safety thermostat, noting the wire numbers.
- 7.5.4 Remove element tray as shown in 7.2
- 7.5.5 Loosen nuts on phial clamps.
- 7.5.6 Carefully pull phial forward free of the clamp.
- 7.5.7 When replacing the phial ensure you re-fit the vidaflex sleeve to the capillary, the capillary is supported in the two guides and the phial is pushed fully in until it hits the end of the phial clamp before fully tightening the clamp nuts.

## 7.6 SAFETY THERMOSTAT RESET (CHROME GRIDDLE ONLY)

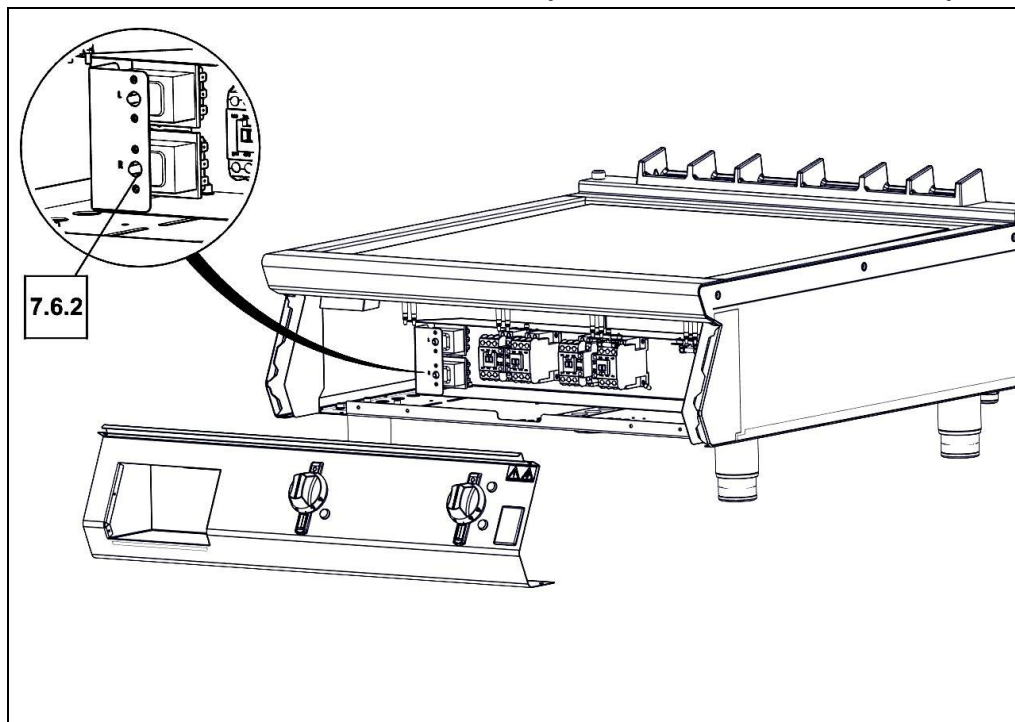

Allow the griddle plate to cool down prior to resetting the thermostat.

- 7.6.1 Remove control panel as shown in 7.1
- 7.6.2 Push in the red reset button with your finger.

**NOTE: Reset button is sensitive. Do not use excessive force.**



**IF THE SAFETY THERMOSTAT HAS ACTIVATED, THE REASON FOR OVERHEATING MUST BE IDENTIFIED AND REMEDIED BEFORE RETURNING THE UNIT TO SERVICE**

**Replace all parts in reverse order**

## 7.7 CIRCUIT DIAGRAMS

### 7.7.1 E9541 / E9541R

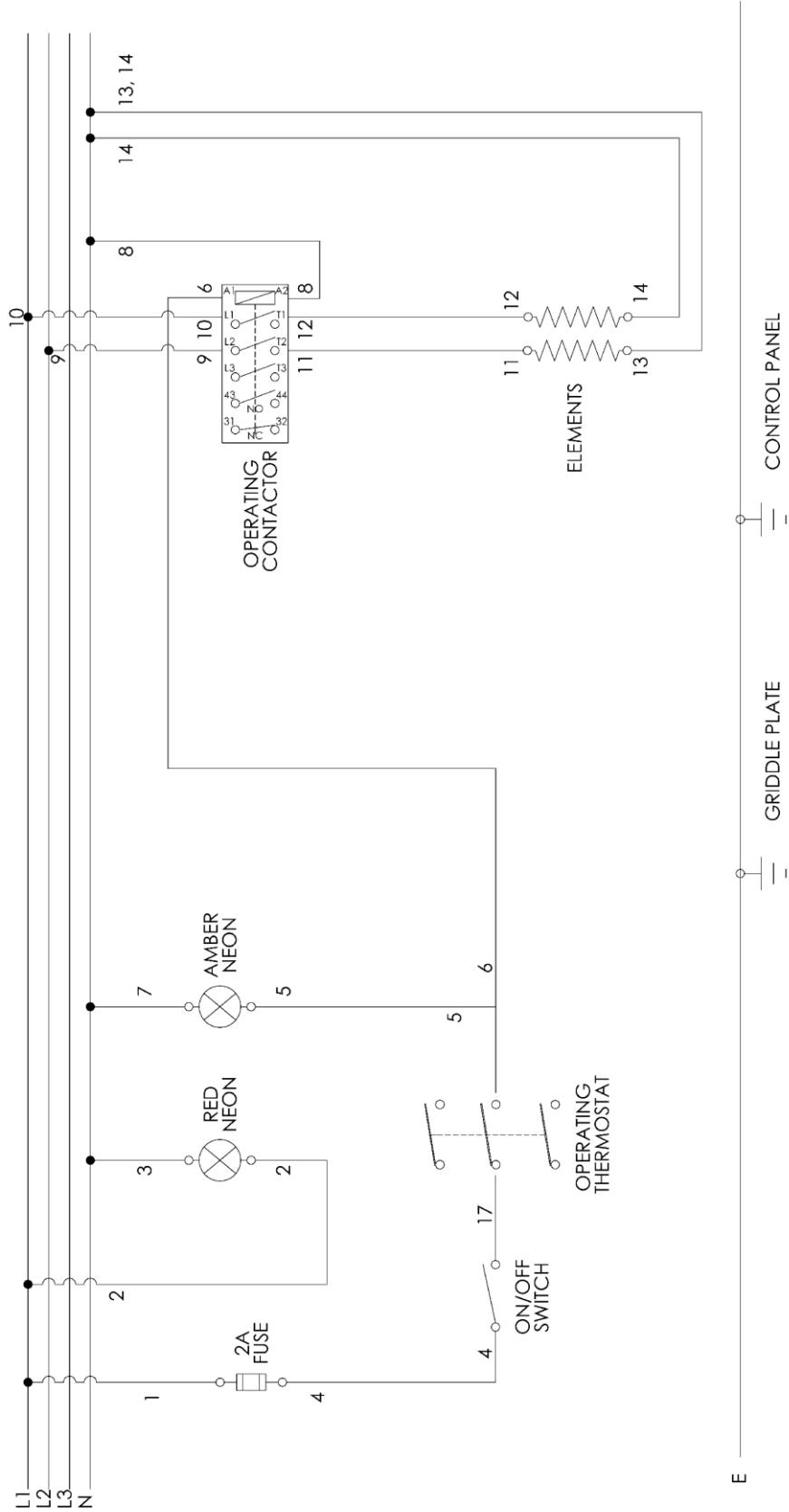

7.7.2 E9541CR

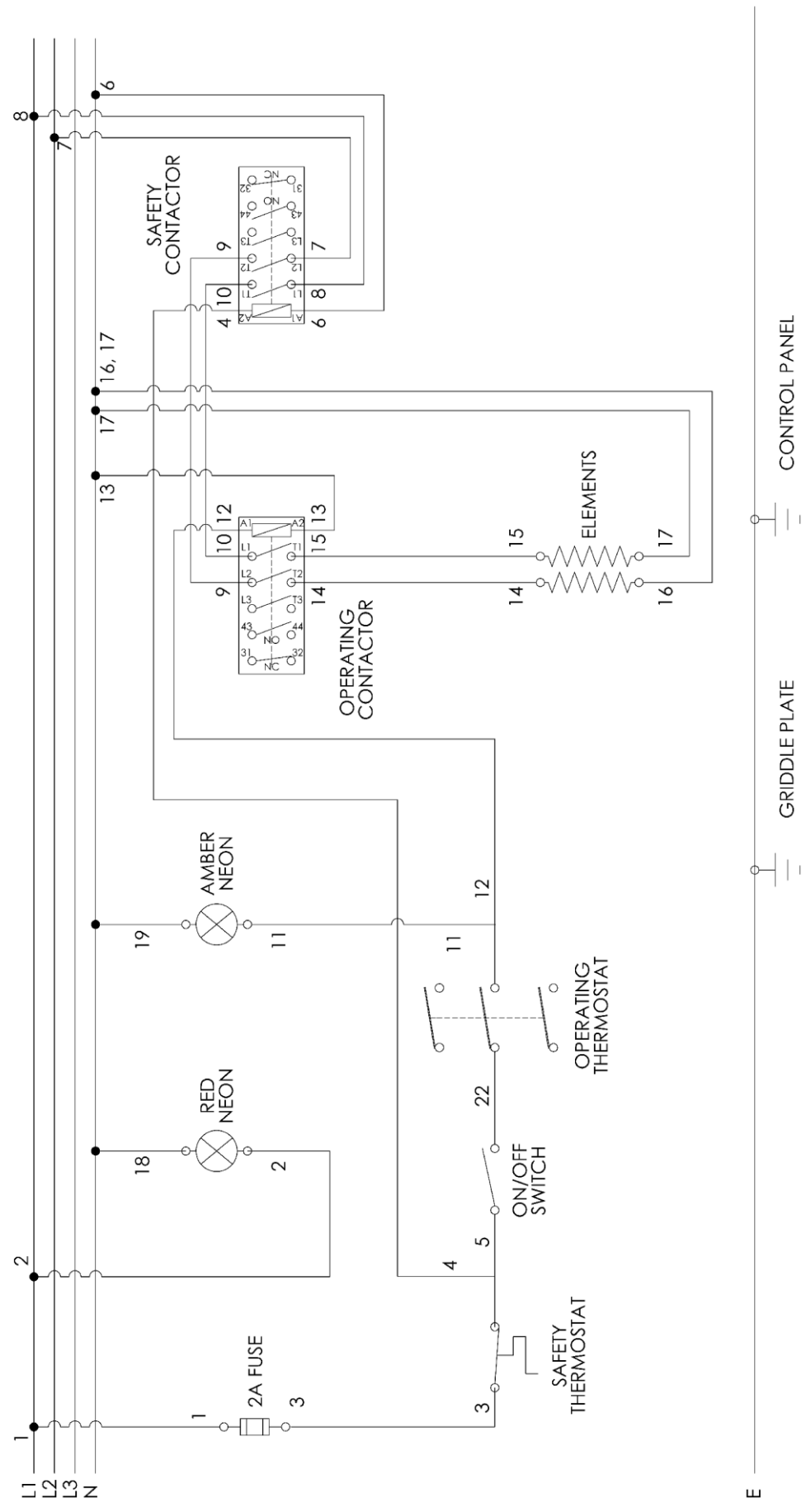

7.7.3 E9581 / E9581R

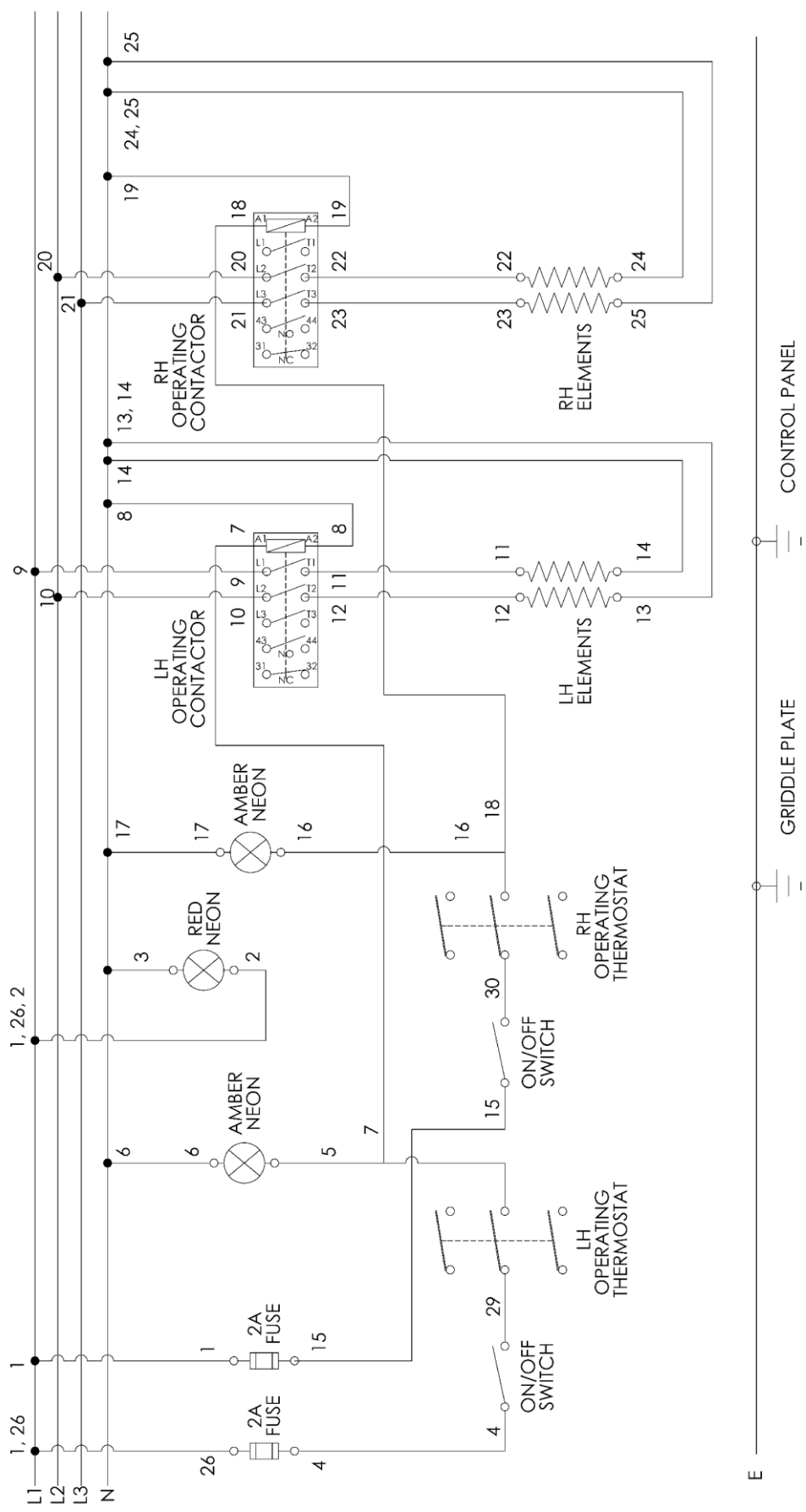



7.7.4 E9581CR

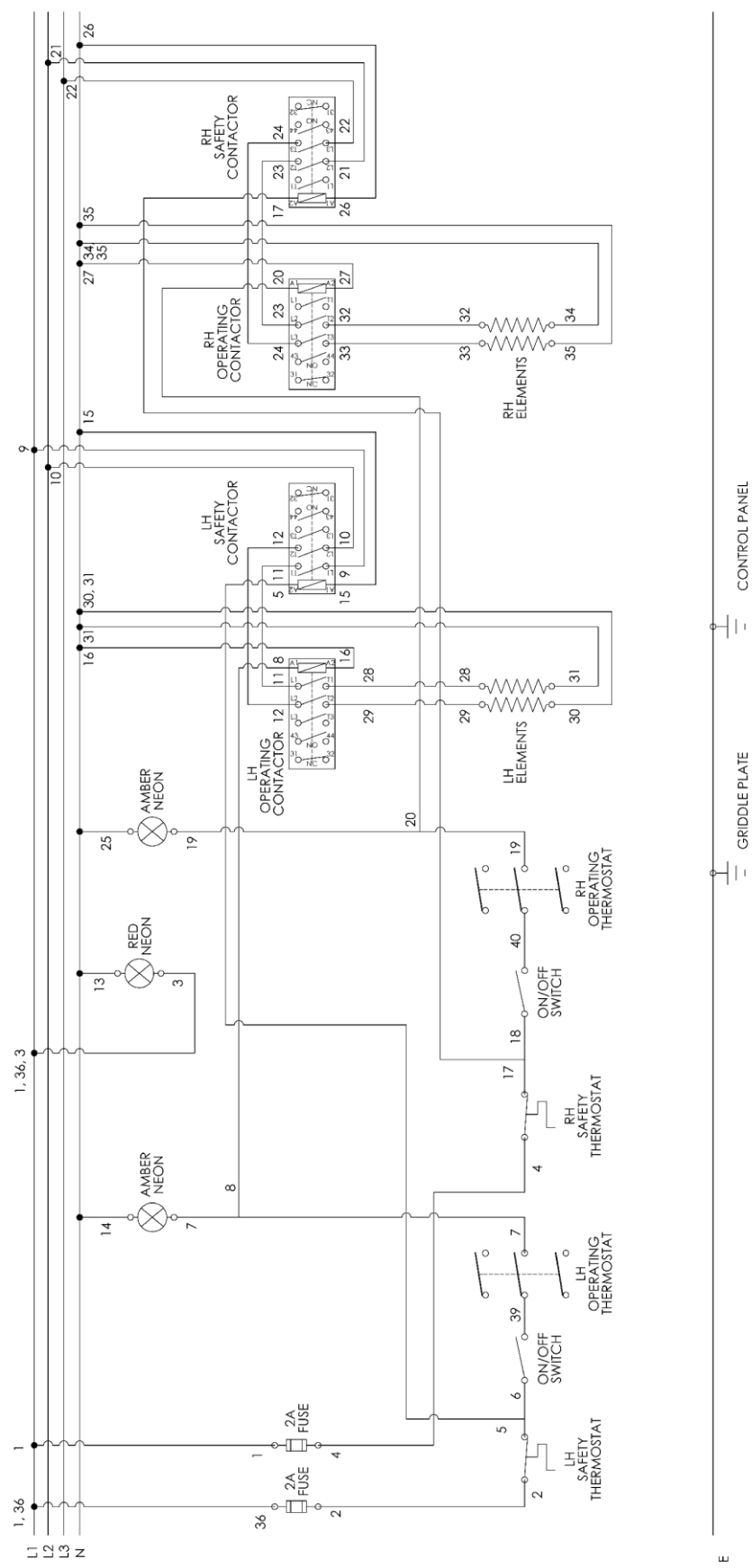

## 7.8 WIRING DIAGRAMS

### 7.8.1 E9541 / E9541R

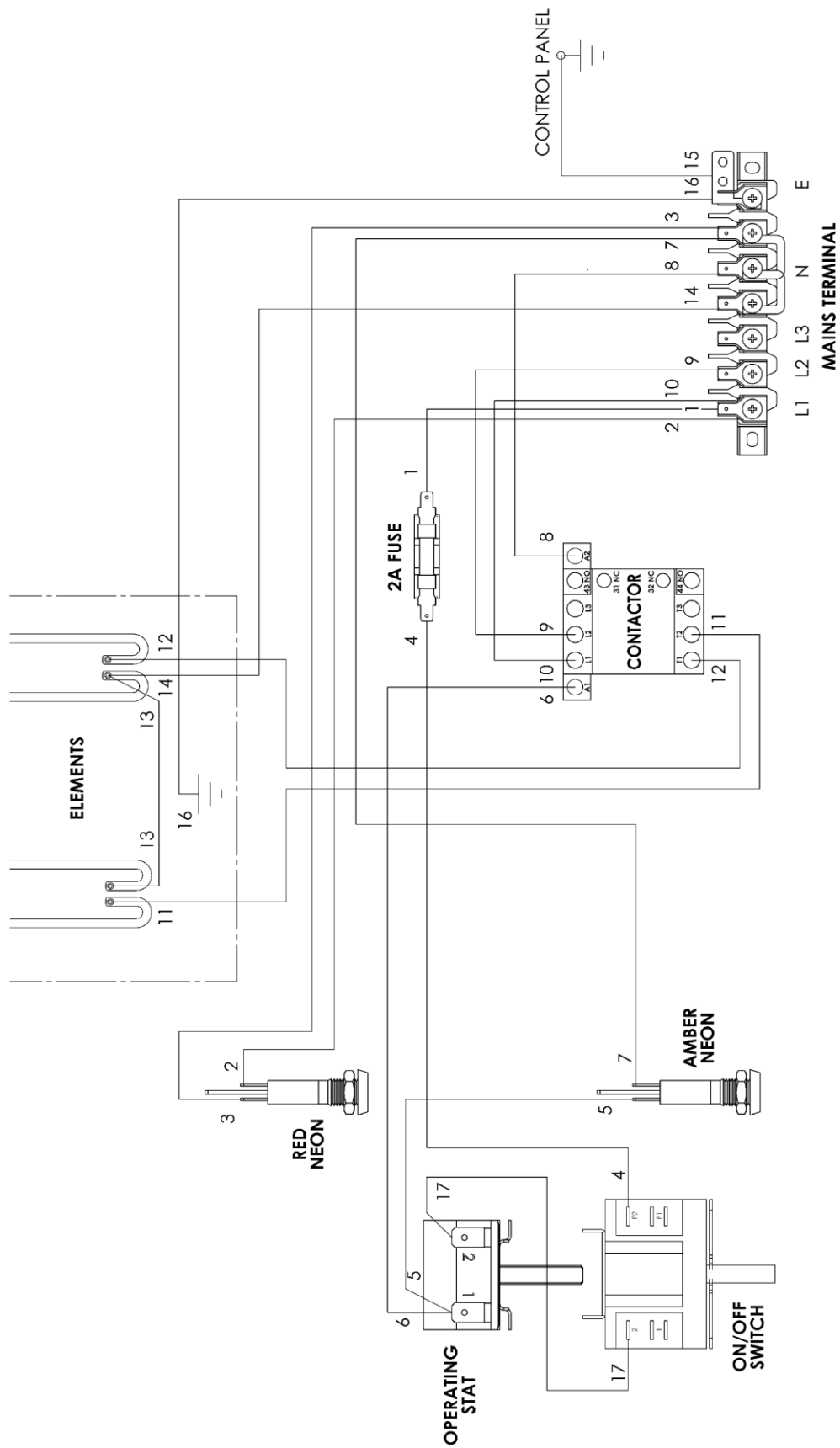

7.8.1 E9541CR

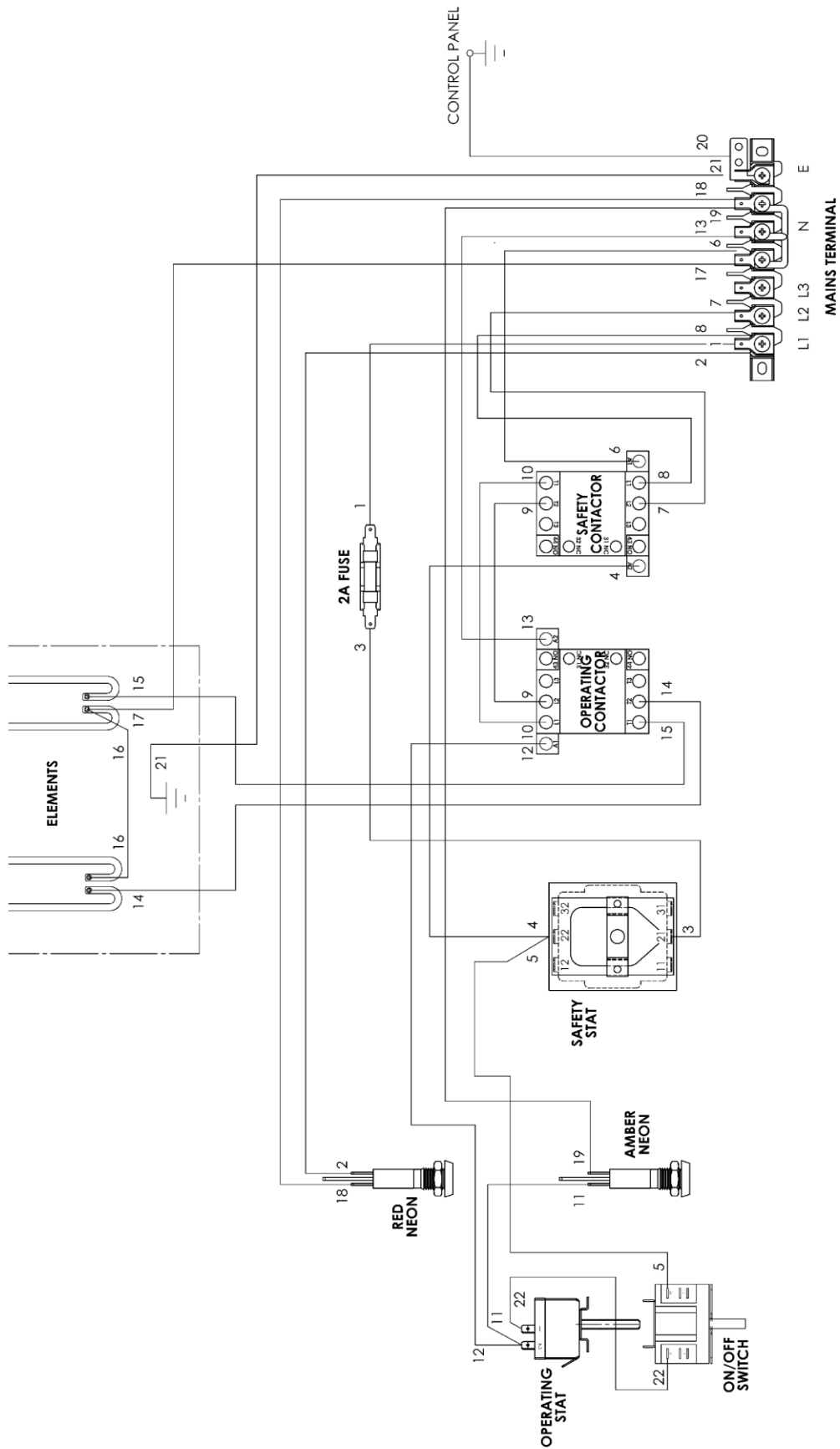

7.8.1 E9581 / E9581R

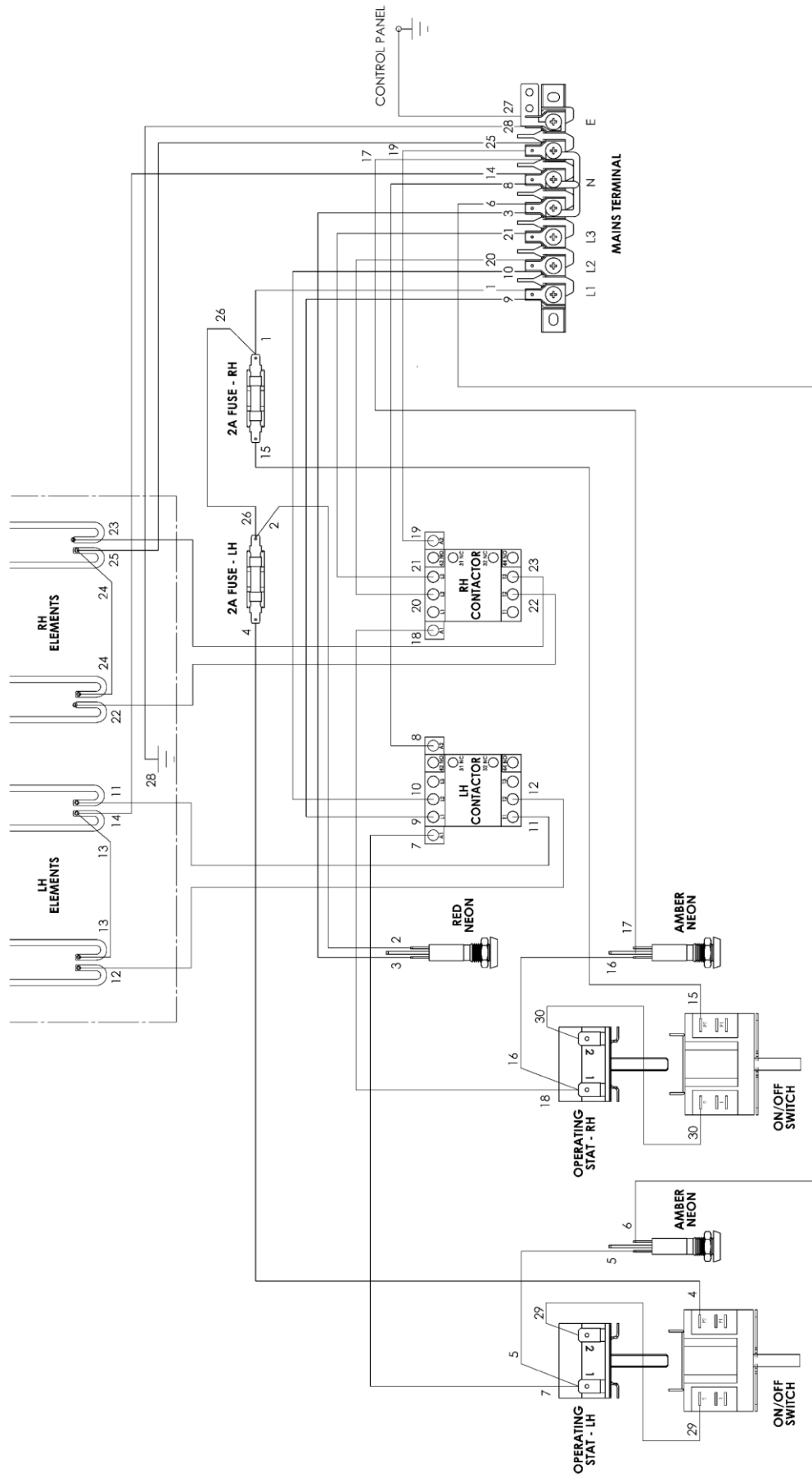

7.8.1 E9581CR

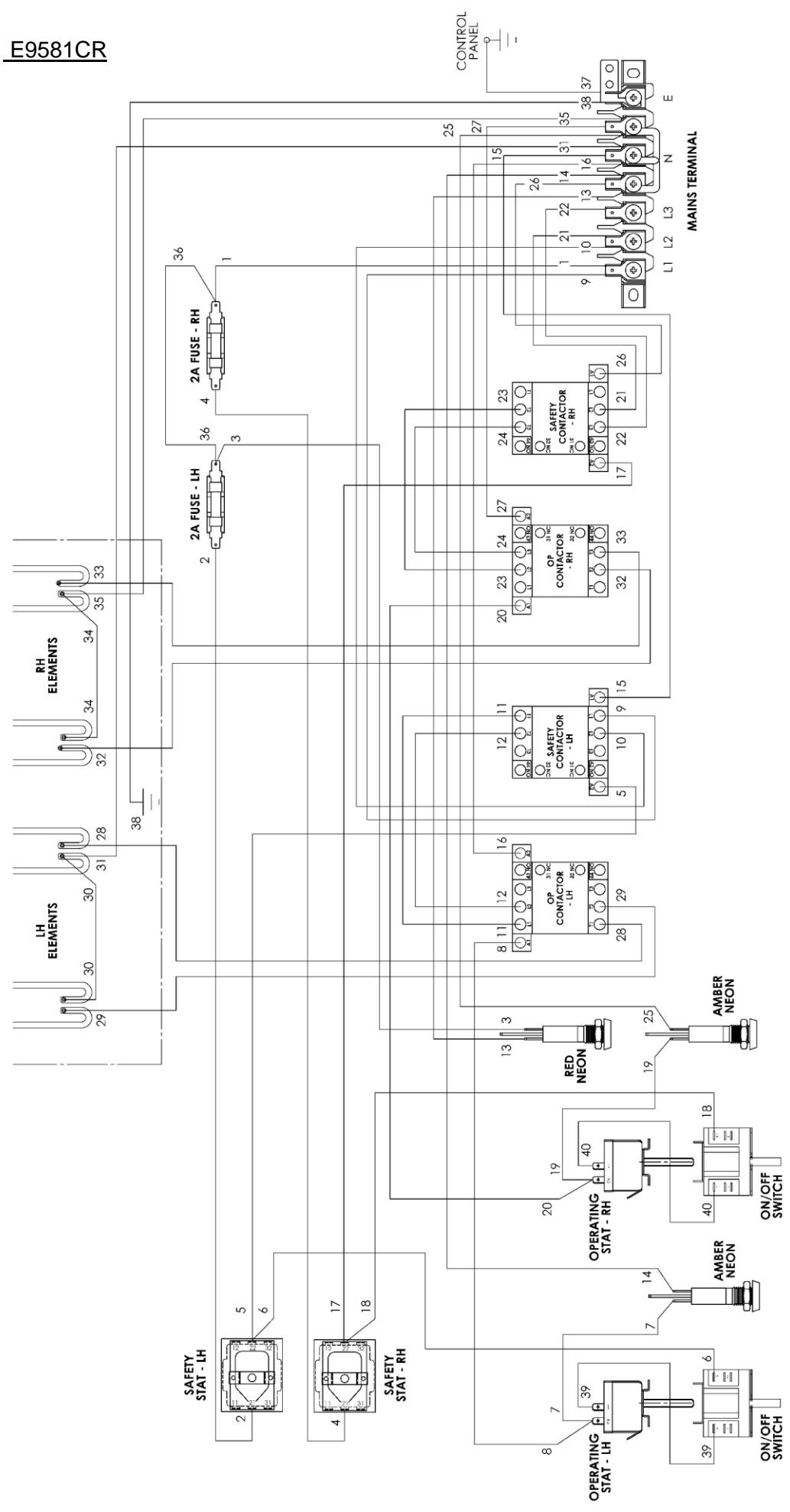

## 8.0 FAULT FINDING

---

FAULT	POSSIBLE CAUSES	REMEDY
No power (red neon extinguished)	Appliance disconnected from mains power	Reconnect to mains power
No heat when thermostat turned on (amber neon extinguished)	Appliance internal fuse blown	Investigate reason, rectify fault, replace fuse
	Faulty thermostat	Replace
	Safety thermostat tripped	Reset/investigate reason
No heat when thermostat turned on (amber neon illuminated)	Faulty contactor	Replace
	Faulty element	Replace
Appliance not hot enough	Faulty thermostat	Replace. <b>Note:</b> when checking plate temperature, probe 210mm in from each side halfway between front and rear on E9581 models. Probe centre plate on E9541 models

## 9.0 SPARE PARTS

---

Mains Pilot light RED	730962010
Circuit Pilot light AMBER	730962040
Element 230V	733620006
Thermostat E9581/81R/41/41R	731910500
Thermostat E9581CR/41CR	733630002
On/Off Switch	732910481
Safety thermostat E9581CR/41CR	733630003
Control knob E9581/81R/41/41R	733620005
Control Knob E9581CR/41CR	733630004

When ordering spares, quote the following:

**Model Number**

**Serial number**

**Gas Type**

This information is found on data plate on front panel. (see section 1.0)

Visit our website for further spares information.

## 10.0 SERVICE INFORMATION

This unit carries an extensive mainland UK warranty. The warranty is in addition to and does not change your statutory or legal rights.

The warranty policy can be found on our website which details the conditions of the warranty and the exclusions.

<https://www.falconfoodservice.com/info-centre/policy>



Service calls to equipment under warranty will be carried out in accordance with the conditions of sale.

Warranty calls can be made between 8:30 am and 5:00 pm weekdays only.

To ensure your warranty enquiry is handled as efficiently as possible, ensure you have the following appliance information prior to calling us:

1. Model number – found on data plate
2. Serial number – found on data plate
3. Brief description of the issue

To contact Falcon for a warranty issue dial (UK only) 01786 455 200 and select Warranty Issues from the menu.