



F900

E9541 Smooth Electric Griddle

Key features

- 18mm thick, machined mild steel smooth griddle plate
 - Quick heat up, even heating across plate
- Thermostatically controlled from 100 - 300°C
 - Precise temperature control
- Large capacity grease collection container
 - Easy to remove and empty during service
- 360° grease trough
 - Easy to discard excess grease and debris
- Large capacity grease collection container
 - Easy to remove and empty during service
- Stainless steel panels with Scotch Brite finish
 - Looks great, ideal for front-of-house kitchens
- Dynamic Link System compatible
 - Integrated linking system allows quick and easy installation to create a seamless, continuous cookline

Accessories

- Fixed stand (ST40)
- Front hob rail
- Kick strip (for stand)
- Rear blanking plate (for stand)
- Side hob extension
- Factory fitted, adjustable castors



Similar Models

- E9541R 400mm wide ribbed electric griddle (F900)
- E9541CR 400mm wide chrome electric griddle (F900)
- E3441 400mm wide electric griddle (Dominador Plus)
- E3441R 400mm wide ribbed electric griddle (Dominador Plus)

F900

E9541

Smooth Electric Griddle

Measurements *in mm*

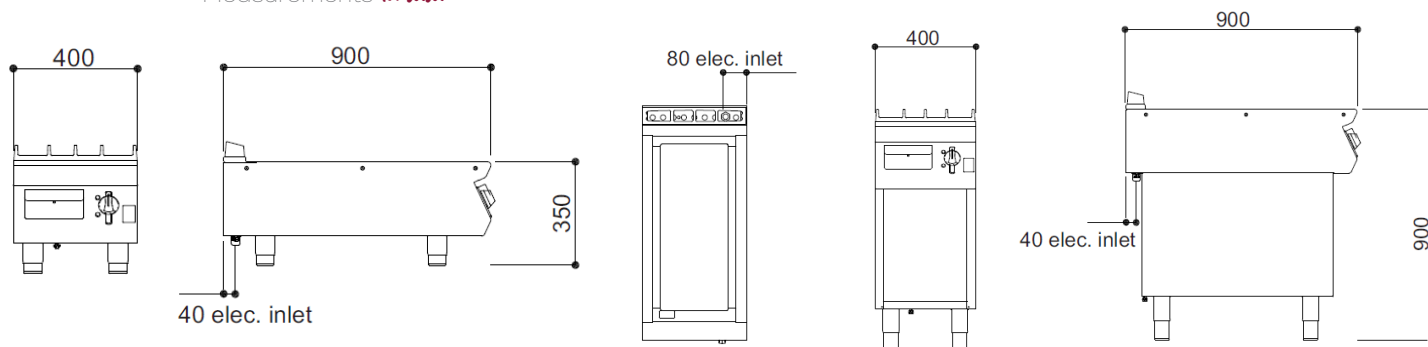

Unit on castors is the same hob height

Specification details

Electrical rating (kW)	4.4
Electrical supply voltage	400V 3N~ 50/60 Hz
Required electrical supply (A)	32
Electrical current split (A)	L1: 9.56, L2: 9.56, L3: 0
Element rating (kW)	2 x 2.2 (single control)
Cooking area (w x d - mm)	260 x 640
Weight (kg)	47
Weight on stand (kg)	60
Packed weight (kg)	55
Packed dimensions (w x d x h - mm)	490 x 1000 x 780
GTIN number	

Short Form specification

Unit to be Falcon F900 Series electric griddle top with 2 x 2.2kW elements below plate. Unit to be supplied upon adjustable feet or installed upon optional base unit.

The cooking surface will be made from 18mm thick highly polished mild steel. The cooking surface will be flush with lateral units and front hob to create a plating area. The unit will be thermostatically controlled from 100 - 300°C. There will be a grease collection area surrounding the cooking zone leading to a grease collection container.

The hob will be constructed from 2mm 304 grade stainless steel. Hobs will be laser cut with right-angled edges to allow joining of units with no gaps between hobs. Exterior panels are Scotch Brite finish stainless steel. Control knobs to be marked showing temperature positions and to have a bezel behind each knob to prevent water ingress.

Installation note

Please consult local legislation with regard to installation of cooking equipment.



Falcon Foodservice Equipment, Wallace View, Hillfoots Road, Stirling FK9 5PY Scotland
t: +44 (0) 1786 455 200 e: info@falconfoodservice.com www.falconfoodservice.com

E9541/SS/1120